



EMERSON MOTOR COMPANY

8100 WEST FLORISSANT AVE.
ST. LOUIS, MO 63136

DATE: 2/17/2011

P.O. NO.:

Order/Line NO.: 21451 MN

TO:

Model Number: DK34
Catalog Number: U1P2DFCR
U1P2DFCR,TEFC,PRE,AC MTR
60/50HZ,208-230/460&190/380V
UTEF,1HP,4P,56C,FTLS

REVISIONS:
(NONE)

**ALL DOCUMENTS HEREIN ARE CONSIDERED CERTIFIED BY US ELECTRICAL MOTORS.
THANK YOU FOR YOUR ORDER AND THE OPPORTUNITY TO SERVE YOU.**

Features:

HorsePower	1
Enclosure.	TE
Poles.	04
RPM (Full Load).	1740 / 1415
Motor Frame Size	56C
Phase.	3
Frequency.	60 / 50
Voltage.	460-230-208 / 380-190
Motor Type Code.	UTEF
Rotor Inertia (LB-FT ²)108 LB-FT ²
Qty. of Bearings PE (Shaft)	1
Qty. of Bearings SE (OPP)	1
Bearing Number PE (Shaft)	6203-2Z-J/C3
Bearing Number SE (OPP)	6203-2Z-J/C3



Emerson Motor Company is a division of Emerson Electric Co.
The Emerson logo is a trademark and service mark of Emerson Electric Co.

EFFECTIVE:
19-OCT-10

HORIZONTAL MOTORS

TEFC

PRINT:
07-1842

SUPERSEDES:
24-JAN-05

FRAME: 56C, B56C
BASIC TYPE: FUTF, UTF, UTEF, UTFI

SHEET:
1 OF 1

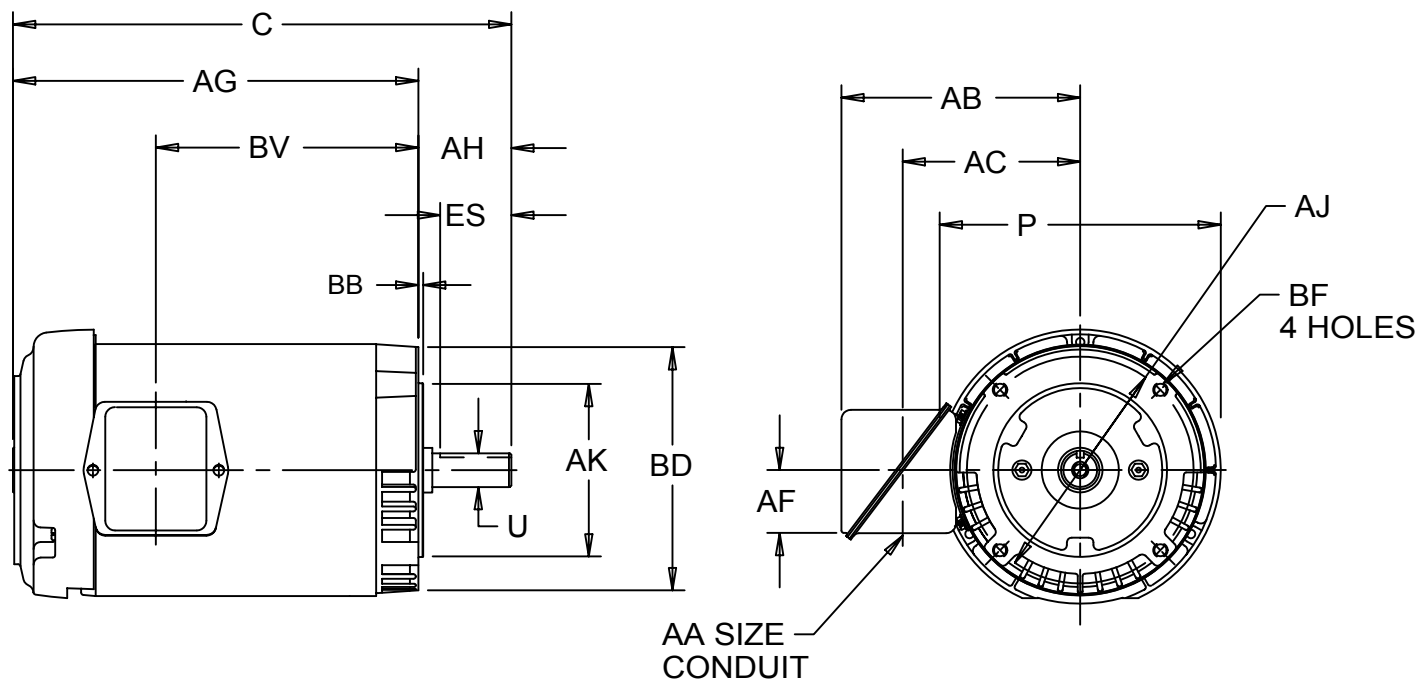

ALL DIMENSIONS ARE IN INCHES AND MILLIMETERS

UNITS	C	P 2	U -.0005	AA	AB	AC	AF	AG	AH
IN	12.06	7.28	.6250	.75	6.09	4.50	1.59	10.00	2.06
MM	306	185	15.875		155	114	40	254	52

UNITS	AJ	AK -.003	BB MIN	BD MAX	BV	BF 3	ES MIN	SQ KEY
IN	5.875	4.500	.13	6.50	6.19	3/8-16 X .75	1.53	.188
MM	149.23	114.30	3	165	157		39	4.78

- 1: ALL ROUGH DIMENSIONS MAY VARY BY .25" DUE TO CASTING AND/OR FABRICATION VARIATIONS.
- 2: LARGEST MOTOR WIDTH.
- 3: TAP SIZE AND BOLT PENETRATION ALLOWANCE.
- 4: ALL TAPPED HOLES ARE UNIFIED NATIONAL COARSE, RIGHT HAND THREAD.

- 5: CONDUIT BOX MAY BE LOCATED ON EITHER SIDE OF MOTOR. CONDUIT OPENINGS MAY BE LOCATED IN STEPS OF 180 DEGREES REGARDLESS OF LOCATION. STANDARD AS SHOWN WITH CONDUIT OPENING DOWN.
- 6: TOLERANCES SHOWN ARE IN INCHES ONLY.
- 7: FRAME REFERENCE: 6.750"/56/B56



NAMEPLATE DATA

<p>CATALOG NUMBER: <input style="width: 150px;" type="text" value="U1P2DFCR"/></p> <p>MODEL <input style="width: 60px;" type="text" value="DK34"/> FR <input style="width: 60px;" type="text" value="56C"/></p> <p>SHAFT END BRG <input style="width: 200px;" type="text" value="6203-2Z-J/C3 - QTY 1"/></p> <p>PH <input style="width: 40px;" type="text" value="3"/> MAX AMB <input style="width: 60px;" type="text" value="40 C"/></p> <p>INSUL CLASS <input style="width: 40px;" type="text" value="F"/> Asm. Pos. <input style="width: 250px;" type="text"/></p> <p>HP <input style="width: 40px;" type="text" value="1"/> RPM <input style="width: 60px;" type="text" value="1740"/></p> <p>VOLTS <input style="width: 60px;" type="text" value="460"/> <input style="width: 60px;" type="text" value="230"/> <input style="width: 60px;" type="text" value="208"/></p> <p>FL AMPS <input style="width: 60px;" type="text" value="1.4"/> <input style="width: 60px;" type="text" value="2.8"/> <input style="width: 60px;" type="text" value="3.0"/></p> <p>SF AMPS <input style="width: 60px;" type="text" value="1.7"/> <input style="width: 60px;" type="text" value="3.3"/></p> <p>SF <input style="width: 40px;" type="text" value="1.25"/> DESIGN <input style="width: 40px;" type="text" value="B"/> CODE <input style="width: 40px;" type="text" value="L"/></p> <p>NEMA NOM EFFICIENCY <input style="width: 60px;" type="text" value="85.5"/> NOM PF <input style="width: 60px;" type="text" value="78.2"/> KiloWatt <input style="width: 60px;" type="text" value=".746"/></p> <p>GUARANTEED EFFICIENCY <input style="width: 60px;" type="text" value="82.5"/> MAX KVAR <input style="width: 60px;" type="text" value=".5"/> HZ <input style="width: 60px;" type="text" value="60"/></p>	<p>NAMEPLATE PART # <input style="width: 150px;" type="text" value="422702-002"/></p> <p>TYPE <input style="width: 60px;" type="text" value="UTEF"/> ENCL <input style="width: 60px;" type="text" value="TE"/></p> <p>OPP END BRG <input style="width: 200px;" type="text" value="6203-2Z-J/C3 - QTY 1"/></p> <p>ID# <input style="width: 300px;" type="text"/></p> <p>DUTY <input style="width: 200px;" type="text" value="CONT"/></p> <p>HP <input style="width: 40px;" type="text" value="1"/> RPM <input style="width: 60px;" type="text" value="1415"/></p> <p>VOLTS <input style="width: 60px;" type="text" value="380"/> <input style="width: 60px;" type="text" value="190"/></p> <p>FL AMPS <input style="width: 60px;" type="text" value="1.7"/> <input style="width: 60px;" type="text" value="3.3"/></p> <p>SF AMPS <input style="width: 60px;" type="text"/></p> <p>SF <input style="width: 40px;" type="text" value="1.00"/> DESIGN <input style="width: 40px;" type="text" value="B"/> CODE <input style="width: 40px;" type="text" value="H"/></p> <p>NEMA NOM EFFICIENCY <input style="width: 60px;" type="text" value="82.5"/> NOM PF <input style="width: 60px;" type="text" value="83.2"/></p> <p>GUARANTEED EFFICIENCY <input style="width: 60px;" type="text" value="80.0"/> MAX KVAR <input style="width: 60px;" type="text" value=".4"/> HZ <input style="width: 60px;" type="text" value="50"/></p>
--	--

UL DATA (IF APPLICABLE):

DIVISION <input style="width: 100px;" type="text"/>	CLASS I <input style="width: 100px;" type="text"/>	GROUP I <input style="width: 100px;" type="text"/>
TEMP CODE <input style="width: 100px;" type="text"/>	CLASS II <input style="width: 100px;" type="text"/>	GROUP II <input style="width: 100px;" type="text"/>

VFD DATA (IF APPLICABLE):

VOLTS <input style="width: 200px;" type="text"/>	
AMPS <input style="width: 200px;" type="text"/>	
TORQUE 1 <input style="width: 200px;" type="text"/>	TORQUE 2 <input style="width: 200px;" type="text"/>
VFD LOAD TYPE 1 <input style="width: 200px;" type="text"/>	VFD LOAD TYPE 2 <input style="width: 200px;" type="text"/>
VFD HERTZ RANGE 1 <input style="width: 200px;" type="text"/>	VFD HERTZ RANGE 2 <input style="width: 200px;" type="text"/>
VFD SPEED RANGE 1 <input style="width: 200px;" type="text"/>	VFD SPEED RANGE 2 <input style="width: 200px;" type="text"/>
SERVICE FACTOR <input style="width: 200px;" type="text"/>	FL SLIP <input style="width: 200px;" type="text"/>
NO. POLES <input style="width: 60px;" type="text" value="4"/>	MAGNETIZING AMPS <input style="width: 60px;" type="text" value=".8"/>
VECTOR MAX RPM <input style="width: 200px;" type="text"/>	Encoder PPR <input style="width: 200px;" type="text"/>
Radians / Seconds <input style="width: 60px;" type="text" value="1"/>	Encoder Volts <input style="width: 200px;" type="text"/>

TEAO DATA (IF APPLICABLE):

HP (AIR OVER) <input style="width: 100px;" type="text"/>	HP (AIR OVER M/S) <input style="width: 100px;" type="text"/>	RPM (AIR OVER) <input style="width: 100px;" type="text"/>	RPM (AIR OVER M/S) <input style="width: 100px;" type="text"/>
FPM AIR VELOCITY <input style="width: 100px;" type="text"/>	FPM AIR VELOCITY M/S <input style="width: 100px;" type="text"/>	FPM AIR VELOCITY SEC <input style="width: 100px;" type="text"/>	

ADDITIONAL NAMEPLATE DATA:

Decal / Plate	WD=344136	Customer PN	
Notes		Non Rev Ratchet	
Max Temp Rise	80C RISE/RES@1.00SF	OPP/Upper Oil Cap	GREASE
Thermal (WDG)		SHAFT/Lower Oil Cap	GREASE
Altitude			
Regulatory Notes		Regulatory Compliance	CC 030A
COS		Marine Duty	
Balance		Arctic Duty	
3/4 Load Eff.	85.8	Inrush Limit	
Motor Weight	30	Direction of Rotation	
Sound Level		Special Note 1	
Vertical Thrust		Special Note 2	
Thrust Percentage		Special Note 3	
Bearing Life		Special Note 4	
Starting Method		Special Note 5	
Number of Starts		Special Note 6	
200/208V 60Hz Max Amps	3.7	SH Max. Temp.	
190V 50 hz Max Amps	3.3	SH Voltage	
380V 50 Hz Max Amps	1.7	SH Watts	
NEMA Inertia		Load Inertia	
Sumpheater Voltage		Sumpheater Wattage	
Special Accessory Note 1		Special Accessory Note 16	
Special Accessory Note 2		Special Accessory Note 17	
Special Accessory Note 3		Special Accessory Note 18	
Special Accessory Note 4		Special Accessory Note 19	
Special Accessory Note 5		Special Accessory Note 20	
Special Accessory Note 6		Special Accessory Note 21	
Special Accessory Note 7		Special Accessory Note 22	
Special Accessory Note 8		Special Accessory Note 23	
Special Accessory Note 9		Special Accessory Note 24	
Special Accessory Note 10		Special Accessory Note 25	
Special Accessory Note 11		Special Accessory Note 26	
Special Accessory Note 12		Special Accessory Note 27	
Special Accessory Note 13		Special Accessory Note 28	
Special Accessory Note 14		Special Accessory Note 29	
Special Accessory Note 15		Special Accessory Note 30	



EMERSON MOTOR COMPANY
ST. LOUIS, MO



TYPICAL NAMEPLATE DATA
ACTUAL MOTOR NAMEPLATE LAYOUT MAY VARY
SOME FIELDS MAY BE OMITTED

MOTOR PERFORMANCE

MODEL NO.	CATALOG NO.	PHASE	TYPE	FRAME
DK34	U1P2DFCR	3	UTEF	56C

ORDER NO.	21451	LINE NO.
-----------	-------	----------

MPI:	135739	135747	135748	135746	135750
HP:	1	1	1	1	1
POLES:	4	4	4	4	4
VOLTS:	460	230	208	380	190
HZ:	60	60	60	50	50
SERVICE FACTOR:	1.25	1.25	1.25	1	1
EFFICIENCY (%):					
S.F.	84.5	84.8	83.2		
FULL	85.5	84	84	82.5	82.5
3/4	85.8	84.7	85.1	84.4	84.4
1/2	83.6	81.7	83.1	83	83
1/4	75.2	71.9	74.6	75.1	75.1
POWER FACTOR (%):					
S.F.	82.9	79.2	83.3		
FULL	78.2	73.3	78.6	79.5	79.5
3/4	70.4	64.4	70.8	71.5	71.5
1/2	57.4	51.1	57.8	58	58
1/4	37.1	32.5	37.4	37.1	37.1
NO LOAD	8.4	8.2	8.6	8.1	8.1
LOCKED ROTOR	62.2	65.2	63.9	70.4	70.4
AMPS:					
S.F.	1.7	3.5	3.7		
FULL	1.4	3	3.1	1.7	3.5
3/4	1.2	2.6	2.6	1.4	2.8
1/2	1	2.2	2.2	1.2	2.4
1/4	0.8	2	1.9	1	2
NO LOAD	0.8	2	1.8	1	1.9
LOCKED ROTOR	11.5	27.1	24.1	12.1	24.3
NEMACODE LETTER	L	M	K	K	K
NEMADESIGN LETTER	B	B	B	B	B
FULL LOAD RPM	1740	1750	1735	1430	1430
NEMA NOMINAL EFFICIENCY (%)	85.5	84	84	82.5	82.5
GUARANTEED EFFICIENCY (%)	82.5	81.5	81.5	80	80
MAX KVAR	0.5	0.7	0.6	0.6	0.5
AMBIENT (°C)	40	40	40	40	40
ALTITUDE (FASL)	3300	3300	3300	3300	3300
SAFE STALL TIME-HOT (SEC)	26	21	27	27	27
SOUND PRESSURE (DBA @ 1M)	0	0	0	0	0
TORQUES:					
BREAKDOWN{% F.L.}	452	523	418	392	392
LOCKED ROTOR{% F.L.}	356	412	324	328	328
FULL LOAD{LB-FT}	3	3	3	3.7	3.7

The Above Data Is Typical. Sinewave Power Unless Noted Otherwise



EMERSON MOTOR COMPANY
ST. LOUIS, MO



Emerson Motor Company is a division of Emerson Electric Co.
The Emerson logo is a trademark and service mark of Emerson Electric Co.



B109144

Motor Wiring Diagram 9 Lead, Dual Voltage (WYE Conn.)

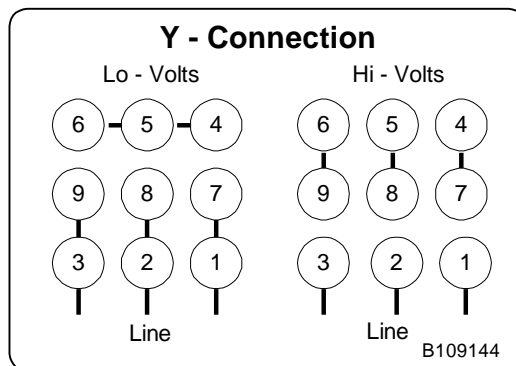
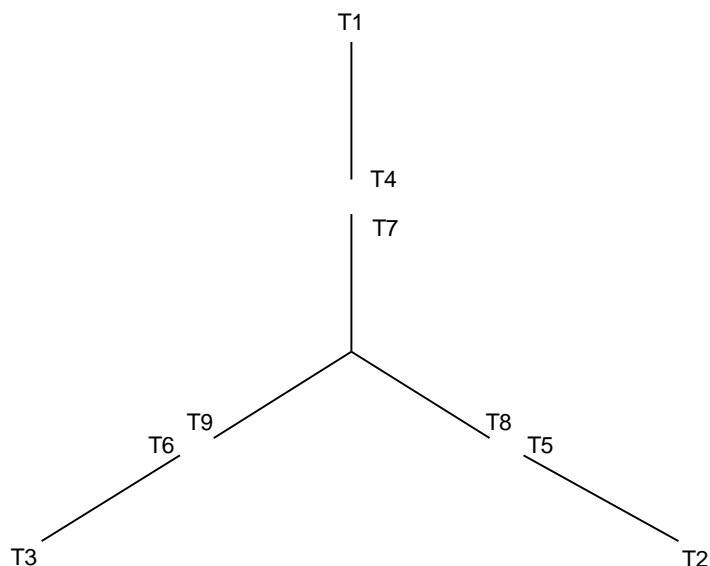

To reverse direction of rotation interchange connections L1 and L2.

Each lead may have one or more cables comprising that lead.
In such case each cable will be marked with the appropriate lead number.

RENEWAL PARTS

FRAMES - 56 THRU B145 UNIMOUNT TOTALLY ENCLOSED MOTORS

TYPES: FUT, FUTF, FUTF4, UT, UT1, UT4, UTE, UTE1, UTE4, UTEF, UTEN, , UTEF1, UTEF4, UTF, UTF1, UTF4, UTFI, UTF4, UTFN, UTI, UTN, UTNI, UTQ, UTV, UTVE

THIS PARTS LIST IS GOOD FOR THE FOLLOWING TYPES:

Types	Frames	Types	Frames
UT, FUT	56, 56C 143T, TC, TD, TCZ 145T, TC, TD, TCZ B145T, TC, TD	UTE, UTQ	143, 145, B145T
UT-1	143, 145, B145JP	UTF	56C, 143TC, TD 145TC, TD
UT-4	143, 145, B145JM	UTN	143, 145T
		UTV	143, 145TCV, JMV, JPV
		UTFN	56C

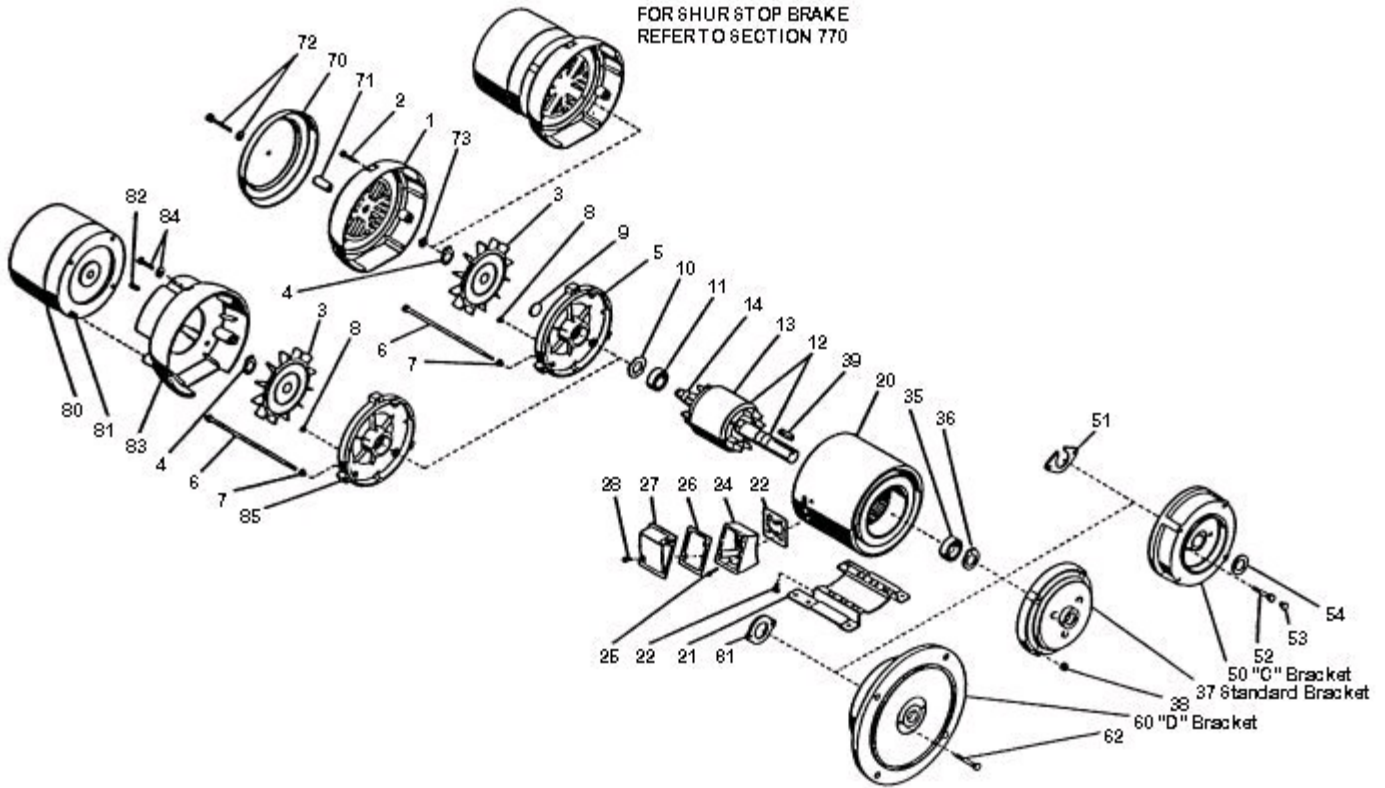

WARNING:

Any disassembly or repair work on explosionproof motors will void the Underwriters Laboratories, Inc. label unless done by the manufacturer, or a facility approved by the Underwriters Laboratories, Inc. Refer to your nearest U.S. Electrical Motors office for assistance.

BEARINGS:

Refer to motor nameplate for the bearing numbers.

PRICES:

Parts stocking distributors: refer to USEM renewal parts numerical index. All Others: refer to your nearest USEM parts distributor.

RENEWAL PARTS

FRAMES - 56 THRU B145 UNIMOUNT TOTALLY ENCLOSED MOTORS

TYPES: FUT, FUTF, FUTF4, UT, UT1, UT4, UTE, UTE1, UTE4, UTEF, UTEN, , UTEF1, UTEF4, UTF, UTF1, UTF4, UTFI, UTFI4, UTFN, UTI, UTN, UTNI, UTQ, UTV, UTVE

ITEM NO.	QTY	NAME OF PART
1	1	Fan Cover (not used on types UTN & UTFN)
2	3	Self Tapping Screw & Lockwasher (not used on types UTN & UTFN)
3	1	Fan (fan assembly on types UTE, 3600 RPM and UTQ) (not used on types UTN & UTFN)
4	1	Retaining Snap Ring (not used on UTE, 3600 RPM and UTN, UTQ and UTFN)
5	1	Bracket
6	4	Round Head Machine Screw
7	4	Bushing
8	4	Plastic Plug
9	1	Bracket Plug (used on types UTN & UTFN only)
10	1	Spring Wave Washer (not on type UTV)
11	1	Ball Bearing
12	1	Rotor Assembly (includes item 12 & 13)
13	1	Rotor Core
14	1	Shaft
15-19	-	Not Used
20	1	Wound Stator Assembly (includes items 21 and 22 if used)
21	1	Mounting Base (not used on types UTF, UTV, UTFN)
22	6	Hex Head Cap Screw (not used on types UTF, UTV, and UTFN)
23	1	Gasket
24	1	Outlet Box Base
25	2	Self Tapping Screw
26	1	Gasket
27	1	Outlet Box Cover
28	2	Self Tapping Screw
29-34	-	Not Used
35	1	Ball Bearing
36	1	Retaining Snap Ring (not used on frames 56 and 56C, also types UTN and UTQ)
37	1	Bracket

WARNING:

Any disassembly or repair work on explosionproof motors will void the Underwriters Laboratories, Inc. label unless done by the manufacturer, or a facility approved by the Underwriters Laboratories, Inc. Refer to your nearest U.S. Electrical Motors office for assistance.

BEARINGS:

Refer to motor nameplate for the bearing numbers.

PRICES:

Parts stocking distributors: refer to USEM renewal parts numerical index. All Others: refer to your nearest USEM parts distributor.

ITEM NO.	QTY	NAME OF PART
38	4	Hex Nut
39	1	Square Key
40-49	-	Not Used
For Types UT, UTF, UTV and UTFN with "C" bracket, and types UT-1 and UT-4 omit items 37, 38 and item 10 on frames 143, 145, and B145		
50	1	"C" Bracket
51	1	Clamping Plate (not used on frame 56C)
52	2	Hex Head Cap Screw (not used on frames 143, 145, & B145)
53	2	Not Used
For types UT and UTF with "D" bracket, omit items 10, 37, and 38, and add the following parts		
60	1	"D" Bracket
61	1	Bearing Cap
62	2	Hex Head Cap Screw
63-69	-	Not Used
For type UTV and units with canopy cap, add the following parts		
70	1	Canopy Cap
71	1	Spacer
72	1	Hex Head Cap Screw and Lockwasher
73	1	Square Nut
74-79	-	Not Used
For SHUR-STOP bakes, omit items 1, 3 and 4, and refer to section 770 for part addition		
For Dings and Stearns brake, omit items 1, 2, and 5, and add the following		
80	1	Brake (for replacement parts for brake, refer to the brake manufacturer)
81	2	Socket Head Cap Screw
82	1	Key
83	1	Bracket Mounting Bracket
84	3	Round Head Machine Screw and Lockwasher
85	1	Bracket

reference: Renewal Parts Section 700, Pages 12 & 13