

NIDEC MOTOR CORPORATION

8050 WEST FLORISSANT AVE.
ST. LOUIS, MO 63136



DATE: 10/29/2015

P.O. NO.: FF44
Order/Line NO.: 23640 MN 100

TO:

Model Number: FF44
Catalog Number:
Steel Frame TEFC Premium Eff.
CONF,MOTOR,STEEL FRAME PRE EFF

REVISIONS:
(NONE)

**ALL DOCUMENTS HEREIN ARE CONSIDERED CERTIFIED BY NIDEC MOTOR CORPORATION.
THANK YOU FOR YOUR ORDER AND THE OPPORTUNITY TO SERVE YOU.**

Features:

Horsepower 00003.00 ~ KW: 2.238
Enclosure TEFC
Poles 04 ~ RPM: 1800
Frame Size 182~T
Phase/Frequency/Voltage.. 3~060~230/460 ~ Random Wound
Service Factor 1.15
Insulation Class Class "F" ~ Insulife 1000
Altitude In Feet (Max) .. 3300 Ft.(1000 M)
Ambient In Degree C (Max) +40 C
Assembly Position "F-1" Assembly Position
Efficiency Class Premium Efficiency
Application Unknown
Customer Part Number
"AK" Dimension (Inches).. NA
Temperature Rise (Sine Wave): "B" Rise @ 1.0 SF (Resist)
Starting Method Direct-On-Line Start
Duty Cycle Continuous Duty
Efficiency Value 89.5 % ~ Typical
Load Inertia (lb-ft²): NEMA ~ NEMA Inertia: 17.00 ~ 1.00
Number Of Starts Per Hour: NEMA
Motor Type Code SE
Rotor Inertia (LB-FT²) .293 LB-FT²
Qty. of Bearings PE (Shaft) 1
Qty. of Bearings SE (OPP) 1
Bearing Number PE (Shaft) 6206-2Z-J/C3
Bearing Number SE (OPP) 6205-2Z-J/C3

Nidec trademarks followed by the ® symbol are registered with the U.S. Patent and Trademark Office.

NIDEC MOTOR CORPORATION

8050 WEST FLORISSANT AVE.
ST. LOUIS, MO 63136



DATE: 10/29/2015

P.O. NO.: FF44
Order/Line NO.: 23640 MN 100

TO:

Model Number: FF44
Catalog Number:
Steel Frame TEFC Premium Eff.
CONF,MOTOR,STEEL FRAME PRE EFF

REVISIONS:
(NONE)

**ALL DOCUMENTS HEREIN ARE CONSIDERED CERTIFIED BY NIDEC MOTOR CORPORATION.
THANK YOU FOR YOUR ORDER AND THE OPPORTUNITY TO SERVE YOU.**

Accessories:

Standard Leadtime: 7-8 WEEKS
Est. Weight (lbs ea): 60 ~ F.O.B.: Monterrey, Mexico

USE THE DATA PROVIDED BELOW TO SELECT THE APPROPRIATE DIMENSION PRINT

Horsepower	3
Pole(s)	04
Voltage(s)	460-230
Frame Size	182T
Shaft U Diameter	1.125
Outlet Box AF	2.13
Outlet Box AA	0.75

Nidec trademarks followed by the ® symbol are registered with the U.S. Patent and Trademark Office.

EFFECTIVE:
21-NOV-12

SUPERSEDES:
13-APR-11

HORIZONTAL MOTORS

TEFC

FRAME: 180T
BASIC TYPE: S

PRINT:
07-2047

SHEET:
1 OF 1

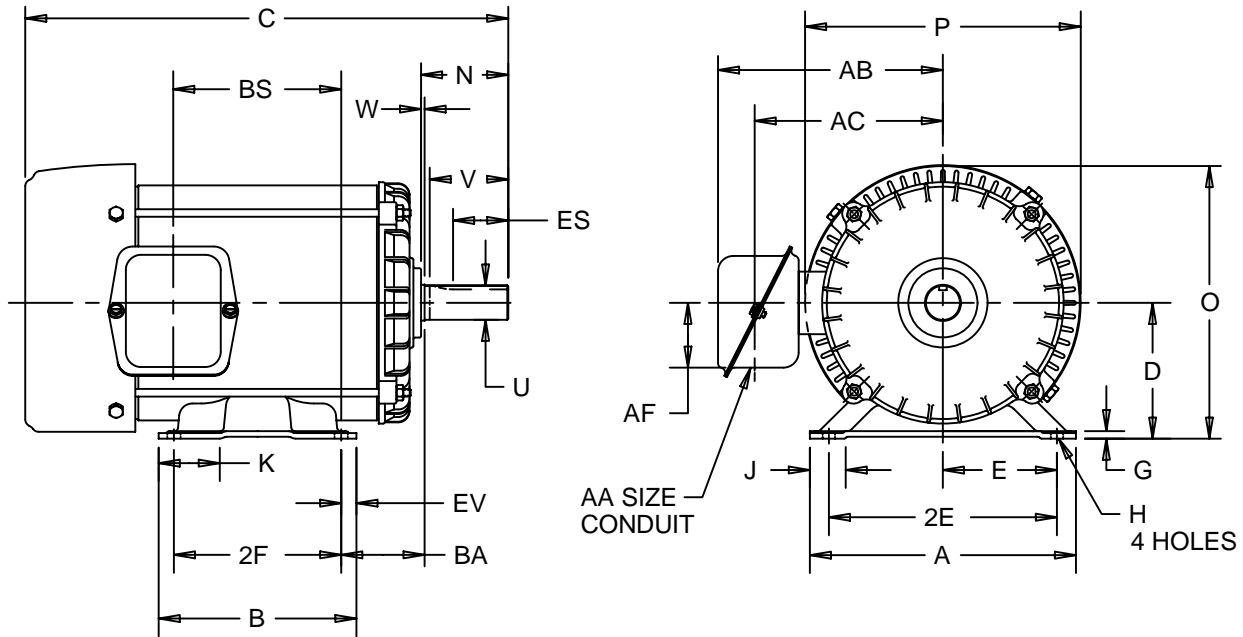

ALL DIMENSIONS ARE IN INCHES AND MILLIMETERS

UNITS	A	B	D -.06	E	G	H +.05	J	K	N	O	P ²	U -.0005
IN	8.75	6.50	4.50	3.75	.18	.44	1.13	2.00	2.88	9.06	9.13	1.1250
MM	222	165	114	95	5	11	29	51	73	230	232	28.575

UNITS	V MIN	W	AA	AB	AC	AF	BA	2E ±.03	ES MIN	EV	SQ KEY
IN	2.56	.13	.75	7.40	6.19	2.13	2.75	7.50	1.78	.50	.250
MM	65	3		188	157	54	70	191	45	13	6.35

BASIC FRAME	UNITS	C	BS	2F ±.03
182T	IN	14.88	4.53	4.50
	MM	378	115	114
184T	IN	15.88	5.53	5.50
	MM	403	140	140

1: ALL ROUGH CASTING DIMENSIONS MAY VARY BY .25" DUE TO CASTING AND/OR FABRICATION VARIATIONS.
2: LARGEST MOTOR WIDTH.
3: TOLERANCES SHOWN ARE IN INCHES ONLY.
4: FRAME REFERENCE: 7.250-182/8.250-184.

07-2047/C

Nidec Motor Corporation
St. Louis, Missouri

INFORMATION DISCLOSED ON THIS DOCUMENT IS CONSIDERED PROPRIETARY AND SHALL NOT BE REPRODUCED OR DISCLOSED WITHOUT WRITTEN CONSENT OF NIDEC MOTOR CORPORATION



ISSUED BY
R. KING
APPROVED BY
J. HAGENE

IHP_DP_NMCA (MAR-2011) SOLIDEDGE

NAMEPLATE DATA

CATALOG NUMBER: _____		NAMEPLATE PART #: 417128-002	
MODEL	FF44	FR	182T
		TYPE	SE ENCL TEFC
SHAFT END BRG		OPP END BRG	
6206-2Z-J/C3 - QTY 1		6205-2Z-J/C3 - QTY 1	
PH	3	MAX AMB	40 C
INSUL CLASS	F	Asm. Pos.	F1
		DUTY	CONT
HP	3	RPM	1765
VOLTS	460 230	HP	_____
FL AMPS	3.9 7.8	VOLTS	_____
SF AMPS	4.4 8.8	FL AMPS	_____
SF	1.15	SF	_____
DESIGN	B	DESIGN	_____
CODE	K	CODE	_____
NEMA NOM EFFICIENCY	89.5	NOM PF	80.2
GUARANTEED EFFICIENCY	87.5	MAX KVAR	1.4
		KiloWatt	2.2
		HZ	60

HAZARDOUS LOCATION DATA (IF APPLICABLE):

DIVISION	_____	CLASS I	_____	GROUP I	_____
TEMP CODE	_____	CLASS II	_____	GROUP II	_____

VFD DATA (IF APPLICABLE):

VOLTS	_____	TORQUE 1	_____	TORQUE 2	_____
AMPS	_____	VFD LOAD TYPE 1	_____	VFD LOAD TYPE 2	_____
		VFD HERTZ RANGE 1	_____	VFD HERTZ RANGE 2	_____
		VFD SPEED RANGE 1	_____	VFD SPEED RANGE 2	_____
SERVICE FACTOR	_____	FL SLIP	_____		
NO. POLES	4	MAGNETIZING AMPS	2.0		
VECTOR MAX RPM	_____	Encoder PPR	_____		
Radians/ Seconds	_____	Encoder Volts	_____		

TEAO DATA (IF APPLICABLE):

HP (AIR OVER)	_____	HP (AIR OVER M/S)	_____	RPM (AIR OVER)	_____	RPM (AIR OVER M/S)	_____
FPM AIR VELOCITY	_____	FPM AIR VELOCITY M/S	_____	FPM AIR VELOCITY SEC	_____		

ADDITIONAL NAMEPLATE DATA:

Decal / Plate	WD=417132	Customer PN	
Notes		Non Rev Ratchet	
Max Temp Rise	80C RISE/RES@1.00SF	OPP/Upper Oil Cap	GREASE
Thermal (WDG)		SHAFT/Lower Oil Cap	GREASE
Altitude			
Regulatory Notes		Regulatory Compliance	
COS		Marine Duty	
Balance		Arctic Duty	
3/4 Load Eff.	89.8	Inrush Limit	
Motor Weight (LBS)	27.24 KG	Direction of Rotation	
Sound Level		Special Note 1	
Vertical Thrust (LBS)		Special Note 2	
Thrust Percentage		Special Note 3	
Bearing Life		Special Note 4	
Starting Method		Special Note 5	
Number of Starts		Special Note 6	
200/208V 60Hz Max Amps		SH Max. Temp.	
190V 50 hz Max Amps		SH Voltage	
380V 50 Hz Max Amps		SH Watts	
NEMA Inertia		Load Inertia	
Sumpheater Voltage		Sumpheater Wattage	
Special Accessory Note 1		Special Accessory Note 16	
Special Accessory Note 2		Special Accessory Note 17	
Special Accessory Note 3		Special Accessory Note 18	
Special Accessory Note 4		Special Accessory Note 19	
Special Accessory Note 5		Special Accessory Note 20	
Special Accessory Note 6		Special Accessory Note 21	
Special Accessory Note 7		Special Accessory Note 22	
Special Accessory Note 8		Special Accessory Note 23	
Special Accessory Note 9		Special Accessory Note 24	
Special Accessory Note 10		Special Accessory Note 25	
Special Accessory Note 11		Special Accessory Note 26	
Special Accessory Note 12		Special Accessory Note 27	
Special Accessory Note 13		Special Accessory Note 28	
Special Accessory Note 14		Special Accessory Note 29	
Special Accessory Note 15		Special Accessory Note 30	

**NIDEC MOTOR CORPORATION
ST. LOUIS, MO**



TYPICAL NAMEPLATE DATA
ACTUAL MOTOR NAMEPLATE LAYOUT MAY VARY
SOME FIELDS MAY BE OMITTED

Nidec trademarks followed by the ® symbol are registered with the U.S. Patent and Trademark Office.

MOTOR PERFORMANCE

MODEL NO.	CATALOG NO.	PHASE	TYPE	FRAME
FF44	NA	3	SE	182T

ORDER NO.	23640	LINE NO.

MPI:	127326	127327
HP:	3	3
POLES:	4	4
VOLTS:	460	230
HZ:	60	60
SERVICE FACTOR:	1.15	1.15
EFFICIENCY (%):		
S.F.	89	89
FULL	89.5	89.5
3/4	89.8	89.8
1/2	88.4	88.4
1/4	82.2	82.2
POWER FACTOR (%):		
S.F.	82.3	82.3
FULL	80.2	80.2
3/4	73.8	73.8
1/2	61.9	61.9
1/4	40	40
NO LOAD	6.7	6.7
LOCKED ROTOR	53.2	53.2
AMPS:		
S.F.	4.4	8.8
FULL	3.9	7.8
3/4	3.2	6.4
1/2	2.6	5.1
1/4	2.1	4.3
NO LOAD	2	4
LOCKED ROTOR	31	62
NEMA CODE LETTER	K	K
NEMA DESIGN LETTER	B	B
FULL LOAD RPM	1765	1765
NEMA NOMINAL EFFICIENCY (%)	89.5	89.5
GUARANTEED EFFICIENCY (%)	87.5	87.5
MAX KVAR	1.4	1.4
AMBIENT (°C)	40	40
ALTITUDE (FASL)	3300	3300
SAFE STALL TIME-HOT (SEC)	13	13
SOUND PRESSURE (DBA @ 1M)	66	66
TORQUES:		
BREAKDOWN{% F.L.}	379	379
LOCKED ROTOR{% F.L.}	242	242
FULL LOAD{LB-FT}	8.9	8.9

NEMA Nominal and Guaranteed Efficiencies are up to 3,300 feet above sea level and 25 ° C ambient

The Above Data Is Typical, Sinewave Power Unless Noted Otherwise

NIDEC MOTOR CORPORATION
ST. LOUIS, MO



Nidec trademarks followed by the ® symbol are registered with the U.S. Patent and Trademark Office.



B109144

Motor Wiring Diagram 9 Lead, Dual Voltage (WYE Conn.)



To reverse direction of rotation interchange connections L1 and L2.

Each lead may have one or more cables comprising that lead.
In such case each cable will be marked with the appropriate lead number.

Suitability of Integral Horsepower (IHP)* Motors on Variable Frequency Drives

Variable Frequency Drives (VFD)

All Nidec Motor Corporation inverter duty motors have 40°C ambient, 1.0 SF on Inverter Power, 3300 ft. max altitude, 460 voltage or less line power, up to 10:1 speed range on Variable Torque and Class F Insulation.

Nidec Motor Corporation's INVERTER GRADE® insulated motors exceeded NEMA® MG-1 Part 30 & 31 before the standards were established.

We are a leader in the development of electric motors to withstand pulse width modulated (PWM) drives evolution from power transistors to higher switching frequency insulated gate bipolar transistors (IGBTs).

Today, as the need for medium duty motor inverter applications grows, Nidec Motor Corporation provides products to meet these demands.

Through continued research and development, Nidec Motor Corporation has included the insulation wire from its INVERTER GRADE® motors in all Premium Efficient motors, enhancing their potential inverter compatibility.

Inverter compatibility with motors is complex. As a result, many variables must be considered when determining the suitability of certain types of motors. These variables include:

- Torque requirements (Constant or Variable)
- Speed Range
- Line/System Voltage
- Cable Length between VFD & Motor
- Drive Switching (Carrier) Frequency Motor Construction
- VFD dv/dt
- High Temperatures High Humidity

Wider speed ranges, higher voltages, higher switching frequencies and increased cable lengths all add to the severity of the application and therefore the potential for premature motor failure. Nidec Motor Corporation has differentiated its products into families for your ease of selection for various inverter applications.

Warranty Guidelines

The information within this section refers to the motor and drive application guidelines and limitations for warranty.

Hazardous Location Motors

Use of a variable frequency drive with the motors in this catalog, intended for use in hazardous locations, is only approved for Division 1, Class I, Group D hazardous location motors with a T2B temperature code, with a limitation of 2:1 constant torque or 10:1 variable torque output. No other stock hazardous location motors are inherently suitable for operation with a variable frequency drive. If other requirements are needed, including non-listed Division 2, please contact your Nidec Motor Corporation territory manager to conduct an engineering inquiry.

575 Volt Motors

575 volt motors can be applied on inverters when output filters are used.

Applying INVERTER GRADE® Insulated Motors on Variable Frequency Drives (2, 4, 6 pole)

The products within this catalog labeled "Inverter Duty" or "Vector Duty" are considered INVERTER GRADE® insulated motors. INVERTER GRADE® motors exceed the NEMA® MG-1 Part 31 standard.

Nidec Motor Corporation provides a three-year limited warranty on all NEMA® frame INVERTER GRADE® insulated motors and allows long cable runs between the motor and the VFD (limited to 400 feet typical without output filters). Cable distance can be further limited by hot and humid environments and VFD manufacturers cable limits. These motors may be appropriate for certain severe inverter application or when the factors relating to the end use application are undefined (such as spares).

Nidec Motor Corporation's U.S. Motors® brand is available in the following INVERTER GRADE® insulated motors:

- Inverter Duty NEMA® frame motors good for 10:1 Variable Torque & 5:1 Constant Torque, including Vertical Type RUSI
- Inverter Duty motors rated for 10:1 Constant Torque
- ACCU-Torq® and Vector Duty Motors with full torque to 0 Speed
- 841 Plus® NEMA® Frame Motors

Applying motors that do not have INVERTER GRADE® insulation on Variable Frequency Drives (2, 4, 6 pole)

Meet NEMA® MG-1, Section IV, Part 31.4.4.2. They can be used with adjustable frequency drives under the following parameters: On NEMA® frame motors, 10:1 speed rating on variable torque loads & 4:1 speed range on constant torque loads. On TITAN® frame motors, 10:1 speed rating on variable torque loads. On TITAN® frame motors, inquiry required for suitability on constant torque loads. Cable distances are for reference only and can be further limited by hot and humid environments. Refer to specific VFD manufacturers cable limits.

Cable Distances			
Maximum Cable Distance VFD to Motor			
Switching Frequency	460 Volt	230 Volt	380 Volt
3 KHz	127 ft	400 ft	218 ft
6 KHz	90 ft	307 ft	154 ft
9 KHz	73 ft	251 ft	126 ft
12 KHz	64 ft	217 ft	109 ft
15 KHz	57 ft	194 ft	98 ft
20 KHz	49 ft	168 ft	85 ft

Applying Standard & Energy Efficient Motors on Variable Frequency Drives is not recommended. VFD related failures on standard and energy efficient motors 444 frame and above will not be covered under warranty.

*This information applies only to Integral Horsepower (IHP) motors as defined on the Agency Approval page, under UL® & CSA® listings where indicated.

† All marks shown within this document are properties of their respective owners.



Motor / Inverter Compatibility

Thermal Overloads and Single Phase Motors

Motors with thermal overloads installed may not operate properly on a VFD. The current carrying thermal overload is designed for sine wave power. Operation on a VFD may cause nuisance tripping or potentially not protect the motor as would be expected on line power. Thermo-stats or thermistors installed in the motor and connected properly to the VFD may provide suitable thermal overload protection when operating on a VFD. (Consult Codes)

Single phase motors and other fractional horsepower ratings are not designed to be operated on a VFD. Within Nidec Motor Corporation standard products, all motors NEMA^{®†} 48 frame (5.5" diameter) and smaller are not suitable for VFD applications. Three phase 56 and 143/145 frame applications should be noted on the catalog price page; or if in doubt ask an Nidec Motor Corporation technical representative for recommendations on compatibility with a VFD.

Slow Speed Motors

Motors with a base design of slower than six poles require special consideration regarding VFD sizing and minimizing harmonic distortion created at the motor terminals due to cable installation characteristics. Additional external PWM waveform filters and shielded motor cables designed for PWM power may be required to provide acceptable motor life. Harmonic distortion on the output waveform should be kept to a minimum level (less than 10%).

690V Applications

Motors that will be applied to 690VAC PWM VFDs require the use of an external filter to limit peak voltage spikes and the use of an INVERTER GRADE[®] motor. Where available, an alternative to using an output filter is to upgrade to a 2300V insulation system.

Low Voltage TITAN[®] Motors

When using 449 frame and larger motors on PWM type VFDs consider the use of an external filter and shielded motor cables designed for PWM power to minimize harmonic distortion and peak voltages at the motor terminals. Harmonic distortion on the output waveform should be kept to a minimum level (less than 10%).

Bearing Currents related to PWM waveform

Due to the uniqueness of this condition occurring in the field, protection of the motor bearings from shaft currents caused by common mode voltages is not a standard feature on sine wave or Inverter Duty motor products, unless explicitly noted. Some installations may be prone to a voltage discharge condition through the motor bearings called fluting.

Fluting damage is related to characteristics of the PWM waveform, VFD programming and characteristics and installation.

Bearing fluting as a result of VFD waveform characteristics may be prevented by the installation of a shaft grounding device such as a brush or ring and/or correction of the installation characteristics causing the shaft voltage condition. Insulated bearing(s) may be required. VFD filters may be needed if bearing fluting is to be avoided.

Multiple Motors on a Single VFD

Special considerations are required when multiple motors are powered from a single VFD unit. Most VFD manufacturers can provide guidelines for proper motor thermal considerations and starting/stopping of motors. Cable runs from the VFD and each motor can create conditions that will cause extra stress on the motor winding. Filters may be required at the motor to provide maximum motor life.

Grounding and Cable Installation Guidelines

Proper output winding and grounding practices can be instrumental in minimizing motor related failures caused by PWM waveform characteristics and installation factors. VFD manufacturers typically provide detailed guidelines on the proper grounding of the motor to the VFD and output cable routing. Cabling manufacturers provide recommended cable types for PWM installations and critical information concerning output wiring impedance and capacitance to ground.

Vertical Motors on VFDs

Vertical motors operated on VFD power present unique conditions that may require consideration by the user or installation engineer:

- Non-reversing-ratchet operation can interfere at low speeds (up to 300 RPM) causing locked rotor and drive tripping.
- Unexpected / unacceptable system vibration and or noise levels caused by the torque pulsation characteristics of the PWM waveform, a system critical frequency falling inside the variable speed range of the process or the added harmonic content of the PWM waveform exciting a system component
- Application related problems related to the controlled acceleration/ deceleration and torque of the motor on VFD power and the building of system pressure/ load.
- The impact the reduction of pump speed has on the down thrust reflected to the pump motor and any minimum thrust requirements of the motor bearings
- Water hammer during shutdown damaging the non-reversing ratchet

Humidity and Non-operational Conditions

The possible build-up of condensation inside the motor due to storage in an uncontrolled environment or non-operational periods in an installation, can lead to an increased rate of premature winding or bearing failures when combined with the stresses associated with PWM waveform characteristics. Moisture and condensation in and on the motor winding over time can provide tracking paths to ground, lower the Megohm resistance of the motor winding to ground, and lower the Corona Inception Voltage level of the winding.

Proper storage and maintenance guidelines are important to minimize the potential of premature failures. Space heaters or trickle voltage heating methods are the preferred methods for drying out a winding that has low megaohm readings. Damage caused by these factors are not covered by the limited warranty provided unless appropriate heating methods are properly utilized during non-operational periods and prior to motor start-up.

**NEMA^{®†} Application Guide for AC Adjustable Speed Drive
Systems: <http://www.nema.org/stds/acadjustable.cfm#download>**

*This information applies only to Integral Horsepower (IHP) motors as defined on the Agency Approval page, under UL^{®†} & CSA^{®†} listings where indicated.

† All marks shown within this document are properties of their respective owners.

